

3M™ Water Filtration Products

SPEC# _____

QUANTITY _____

application:

SCALE CONTROL

model:

SF165



The 3M™ Water Filtration Products SF165 ScaleGARD™ HT System helps provide consistent Recipe Quality Water™ with reduced sediment and chlorine taste and odor. Operating cost savings from the controlled and metered addition of scale-inhibitors reduces the ability of calcium and magnesium to precipitate as hard scale in both high and low temperature applications, including ice machines, coffee, tea, espresso brewers and steamers*.

- ScaleGARD HT, SF165 combines chlorine taste and odor reduction with sediment reduction and helps protect against the effects of scale formation at flow rates to 3.34 gpm (12.6 lpm) for 35,000 gallons (132,000 liters).

PRODUCT BENEFITS

- Advanced Integrated Membrane Pre-Activated Carbon Technology (“IMPACT”) filtration media combines a membrane in series with premium activated carbon to provide superior throughput and cartridge life.
- Reduced sediment and chlorine taste and odor for equipment protection and great tasting hot and cold beverages and ice.
- A forced-feed orifice carefully controls and meters the addition of a proprietary scale inhibitor to reduce scale build-up on heating coils.
- Superior scale reduction performance in equipment from ice machines to equipment heating water to temperatures over 200°F (93°C).
- Sanitary Quick Change (SQC) HF65 encapsulated cartridge design allows for fast and easy change-outs with a 1/4 turn while minimizing the possibility of leakage and media contamination.
- 3/4” NPT inlet and outlet ports allow direct or easily adaptable connections to existing plumbing lines.
- FDA CFR-21 and/or NSF compliant materials.
- System includes a pressure gauge, inlet shut-off valve and outlet check valve for simple installation and operation.

PRODUCT SPECIFICATIONS

Model Number	Part Number	Reduction Claims	Micron Rating	Capacity	Service Flow Rate	Application	Replacement Cartridge	Sizing
SF165	56246-01	Sediment, Chlorine Taste and Odor, Scale	3	35,000 gallons (132,000 liters)	3.34 gpm (12.6 lpm)	Normal to Hard Water	HF65 (56134-07) HF8-S (55821-06) Cartpak (56138-11)	Ice: Cubers to 1,200 lbs. (544 kg) Flakers to 2,400 lbs. (1,089 kg) Coffee Brewers and Steamers to demand flow rates of 3.34 gpm (12.6 lpm)

* Periodic acid de-liming of boiler is recommended for steamer applications.

SF165

SPEC# _____
QUANTITY _____
MODEL NUMBER _____
PART NUMBER _____

Water Filtration Products

PHYSICAL SPECIFICATIONS

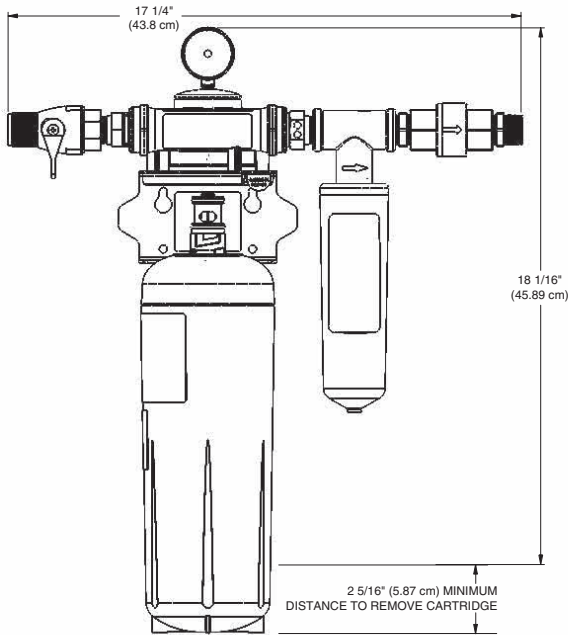

- System includes a manifold with built-in pressure gauge, inlet water shut-off valve, outlet check valve, mounting bracket, filter cartridge and scale-feeding system.
- Inlet and outlet plumbing connections are 3/4" NPT.
- Filter cartridges are o-ring seal type.
- System maximum operating pressure of 125 psi (862 kPa) and operating temperatures of 100°F (37.8°C).
- Recommended service flow rate is up to 3.34 gpm (12.6 lpm)
- Filter cartridge incorporates carbon block media protected by a pleated pre-filter membrane.
- All wetted parts and media are FDA CFR-21 compliant.
- Cartridges are sanitary in design, requiring no contact with the filter media during cartridge change-out.
- Filter cartridges requires no pre-activation.
- Shipping Weight: 6 lbs. (2.7 kg).
- Operating Weight: 12 lbs. (5.4 kg).

IMPORTANT: INSTALLATION TIPS

These installation tips are for informational purposes only and are not intended to be used as actual installation instructions. **CAUTION: To reduce the risk associated with property damage due to water leakage:**

- **Read and follow** Use Instructions before installation and use of this system.
- Installation and use **MUST** comply with all state and local plumbing codes.
- **Protect from freezing**, remove filter cartridge when temperatures are expected to drop below 40°F (4.4°C).
- **Do not install on hot water supply lines.** The maximum operating water temperature of this filter system is 100°F (37.8°C).
- **Do not install** if water pressure exceeds 125 psi (862 kPa). If your water pressure exceeds 80 psi (552 kPa), you must install a pressure limiting valve. Contact a plumbing professional if you are uncertain how to check your water pressure.
- **Do not install** where water hammer conditions may occur. If water hammer conditions exist you must install a water hammer arrester. Contact a plumbing professional if you are uncertain how to check for this condition.
- The disposable filter cartridge **MUST** be replaced every 12 months, at the rated capacity or if a noticeable reduction in flow rate occurs.

⚠ WARNING: To reduce the risk associated with the ingestion of contaminants:

- Do not use with water that is microbiologically unsafe or of unknown quality without adequate disinfection before or after the system.

CUNO Incorporated recommends regularly scheduled maintenance and replacement of the filter cartridge(s) in order for the product to perform as advertised/sold. CUNO shall not be liable for system failures due to improper maintenance.

LIMITED WARRANTY

CUNO Incorporated warrants this Product (excluding disposable filter cartridge(s)) to be free from defects in material and workmanship for five (5) years from the date of purchase. The disposable filter cartridge is warranted from defects in material and workmanship for a period of one (1) year from the date of purchase. This warranty does not cover failures resulting from abuse, misuse, alteration or damage not caused by CUNO or failure to follow installation and use instructions. If the Product is defective CUNO will replace the Product or refund your Product purchase price. CUNO will not be liable for any indirect, special, incidental, or consequential damages arising from the use of this Product. Some states do not allow the exclusion or limitation of incidental or consequential damages, so the above limitation may not apply to you. To obtain warranty service, mail your request to Warranty Claims, CUNO Incorporated, 400 Research Parkway, Meriden, CT 06450. Proof of purchase (original sales receipt) must accompany the warranty claim, along with a complete description of the Product, model number and alleged defect. This warranty gives you specific legal rights and you may have other rights which vary from state to state, or country to country.



CUNO Incorporated
400 Research Parkway
Meriden, CT 06450 U.S.A.
Toll Free: 1.800.222.7880
Worldwide: 203.237.5541
Fax: 203.238.8701
www.cuno.com