

Water Filtration Products

SPEC# _____

QUANTITY _____

application: **COLD BEVERAGE**

models:

BEV160/BEV165



Products Models BEV160 and BEV165 single cartridge water filtration systems help to improve the taste, appearance and consistency of your beverages at flow rates up to 3.34 gpm (12.6 lpm).

- **BEV160** combines cyst and bacteria¹ reduction with sediment and chlorine taste and odor reduction for up to 35,000 gallons (132,489 liters).
- **BEV165** combines sediment reduction from higher turbidity water with chlorine taste and odor reduction for up to 35,000 gallons (132,489 liters).

PRODUCT BENEFITS

- Consistent high-quality, great tasting beverages for continued customer satisfaction.
- Revolutionary **I**ntegrated **M**embrane **P**re-**A**ctivated **C**arbon **T**echnology (“**IMPACT**”) dual-zone media cartridge construction combines a membrane in series with premium activated carbon to provide superior throughput and cartridge life.
- Built-in bacteria inhibitor intended to reduce fouling of media (HF60 replacement cartridge).
- Tested and verified by manufacturer’s laboratory to Standard 53 for cyst reduction (HF60 replacement cartridge).
- NSF Standard 42 and/or FDA CFR-21 compliant materials.
- Reduction of up to 99.99% of common water-borne heterotrophic bacteria by membrane filtration as tested by 3M Purification (HF60 replacement cartridge).
- Reduction of sediment and abrasive hard particles help prevent equipment wear and help extend the life of pumps, valves, o-rings and seals.
- System includes a pressure gauge and inlet shut-off valve for simple installation and operation.
- Sanitary Quick Change (SQC) encapsulated cartridge design allows for fast and easy cartridge change-outs with a 1/4 turn.
- 1/2” FNPT horizontal inlet and outlet ports allow direct or easily adaptable connections to existing plumbing lines.

PRODUCT SPECIFICATIONS

Model Number	Part Number	Reduction Claims	Nominal Micron Rating	Capacity	Service Flow Rate	Application	Replacement Cartridge	Sizing
BEV160	56163-01	Cyst, Bacteria ¹ , Sediment, Chlorine Taste and Odor	0.2 ²	35,000 gallons (132,489 liters)	3.34 gpm (12.6 lpm)	Most Standard Water	HF60: 56134-03	Dual Carbonator Dispenser
BEV165	56163-02	Sediment, Chlorine Taste and Odor	3.0 ²	35,000 gallons (132,489 liters)	3.34 gpm (12.6 lpm)	Higher Turbidity Water	HF65: 56134-07	Dual Carbonator Dispenser

¹As tested with either E.Coli ATCC (11229) or Pseudomonas (B) diminuta ATCC (19146)

²Tested and verified by manufacturer’s laboratory for Particulate, Class I

BEV160/BEV165

SPEC# _____
QUANTITY _____
MODEL NUMBER _____
PART NUMBER _____

Water Filtration Products

PHYSICAL SPECIFICATIONS

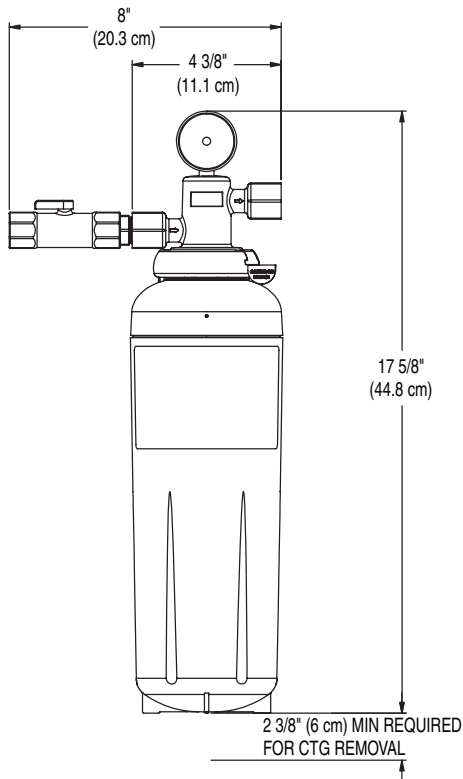

- System includes a head assembly with pressure gauge, inlet water shut-off valve assembly, mounting bracket and a single cartridge filter.
- Inlet and outlet plumbing connections are 1/2" FNPT.
- Filter cartridges are o-ring seal type.
- System maximum operating pressure of 125 psi (862 kPa) and operating temperature of 100°F (37.8°C).
- Recommended service flow rate is up to 3.34 gpm (12.6 lpm).
- Filter cartridges incorporate a bacteriostatic carbon block filtration medium (HF60 replacement cartridge).
- System materials are NSF Standard 42 and/or FDA CFR-21 compliant.
- Cartridges are sanitary in design, requiring no contact with the filter media during cartridge change-out.
- Filter cartridges require no pre-activation.
- NSF Performance Data Sheet (PDS) is included.
- Shipping weight: 4.1 lbs. (1.9 kg) per case.
- Operating weight: 7.5 lbs. (3.4 kg) per case.

IMPORTANT: INSTALLATION TIPS

These installation tips are for informational purposes only and are not intended to be used as actual installation instructions. **CAUTION: To reduce the risk associated with property damage due to water leakage:**

- **Read and follow** Use Instructions before installation and use of this system.
- Installation and use **MUST** comply with all state and local plumbing codes.
- **Protect from freezing**, remove filter cartridge when temperatures are expected to drop below 40°F (4.4°C).
- **Do not install on hot water supply lines.** The maximum operating water temperature of this filter system is 100°F (37.8°C).
- **Do not install** if water pressure exceeds 125 psi (862 kPa). If your water pressure exceeds 80 psi (552 kPa), you must install a pressure limiting valve. Contact a plumbing professional if you are uncertain how to check your water pressure.
- **Do not install** where water hammer conditions may occur. If water hammer conditions exist you must install a water hammer arrester. Contact a plumbing professional if you are uncertain how to check for this condition.
- The disposable filter cartridge **MUST** be replaced every 12 months, at the rated capacity or if a noticeable reduction in flow rate occurs.

⚠ WARNING: To reduce the risk associated with the ingestion of contaminants:

- **Do not use with water that is microbiologically unsafe or of unknown quality without adequate disinfection before or after the system.** Systems certified for cyst reduction may be used on disinfected water that may contain filterable cysts. EPA Establishment #070595-CT-001

3M Purification Inc. recommends regularly scheduled maintenance and replacement of the filter cartridge(s) in order for the product to perform as advertised/sold. 3M Purification shall not be liable for system failures due to improper maintenance.

LIMITED WARRANTY

3M Purification Inc. warrants this Product will be free from defects in material and manufacture for five (5) years from the date of purchase: The filter cartridge or filter membrane is warranted to be free from defects in material and manufacture for one (1) year. This warranty does not cover failures resulting from abuse, misuse, alteration or damage not caused by 3M Purification Inc. or failure to follow installation and use instructions. No warranty is given as to the service life of any filter cartridge or membrane as it will vary with local water conditions and water consumption. **3M PURIFICATION INC. MAKES NO OTHER WARRANTIES OR CONDITIONS, EXPRESS OR IMPLIED, INCLUDING, BUT NOT LIMITED TO, ANY IMPLIED WARRANTY OR CONDITION OF MERCHANTABILITY OR FITNESS FOR A PARTICULAR PURPOSE OR ANY IMPLIED WARRANTY OR CONDITION ARISING OUT OF A COURSE OF DEALING, CUSTOMER OR USAGE OF TRADE.** If the Product fails to satisfy this Limited Warranty during the warranty period, 3M Purification Inc. will replace the Product or refund your Product purchase price. This warranty does not cover labor. **The remedy stated in this paragraph is Customer's sole remedy and 3M Purification Inc.'s exclusive obligation. For additional information, see the entire Limited Warranty located in the product Installation and Operating Instruction Manual.**

Limitation of Liability: 3M Purification Inc. will not be liable for any loss or damage arising from this 3M Purification Inc. product, whether direct, indirect, special, incidental, or consequential, regardless of the legal theory asserted, including warranty, contract, negligence or strict liability. Some states and countries do not allow the exclusion or limitation of incidental or consequential damages, so the above limitation or exclusion may not apply to you.



400 Research Parkway
Meriden, CT 06450 U.S.A.
Toll Free: 1.800.243.6894
Worldwide: 203.237.5541
Fax: 203.630.4530
www.3Mpurification.com



Visit www.nsf.org for the claims associated with products that are NSF listed.

70-0201-9413-3
Please recycle. Printed in U.S.A.