



## APPLICATION: Water Softening



The 3M™ Water Softeners Series Models 3MWTS100, 3MWTS150 & 3MWTS200 treat water as it enters your home, minimizing the effects of hard water. Benefits include brighter clothing, cleaner dishes, less detergent consumption and less water usage. Helps protect the entire plumbing system. System includes a state-of-the-art valve that allows monitoring and control for every function and cycle. Saves water by metering use and regenerating only when necessary. The multi-level salt support traps dirt (sediment) and debris away from the brine draw area, enabling the use of inexpensive types of water treatment salt reducing maintenance. The valve includes a bypass assembly for yard and garden watering.

### PRODUCT BENEFITS:

- Extremely easy to use state-of-the-art water softening valve.
- Superior performance brine tank featuring a durable design which provides virtually trouble-free operation. Includes salt shelf.
- Engineered system design helps provide long-term operation. Quality factory support and service available.

**MODELS: 3MWTS100/3MWTS150/3MWTS200**

### PRODUCT SPECIFICATIONS:

Model/Part Number	Maximum Operating Temperature	Operating Pressure	Electrical Requirements	Pipe Size	Mineral Tank (D x H)	Brine Tank (W x D x H)	Minimum Space Requirements*		
							Width (A)	Height (B)	Depth (C)
3MWTS100	110°F (43.3°C)	20 - 125 psi (138 - 862 kPa)	110/120V, 60Hz	1" NPT	8" x 44" (21 cm x 112 cm)	15" x 15" x 34" (38 cm x 38 cm x 87 cm)	33" (84 cm)	53" (135 cm)	15" (135 cm)
3MWTS150	110°F (43.3°C)	20 - 125 psi (138 - 862 kPa)	110/120V, 60Hz	1" NPT	10" x 44" (26 cm x 112 cm)	15" x 15" x 34" (38 cm x 38 cm x 87 cm)	35" (89 cm)	53" (135 cm)	15" (135 cm)
3MWTS200	110°F (43.3°C)	20 - 125 psi (138 - 862 kPa)	110/120V, 60Hz	1" NPT	10" x 54" (26 cm x 137 cm)	15" x 15" x 34" (38 cm x 38 cm x 87 cm)	35" (89 cm)	63" (160 cm)	15" (135 cm)

\* Please refer to diagram on back of specification sheet

To obtain additional information please call our Customer Care team at 855-3M-WATER or visit our website at [www.3MWater.com](http://www.3MWater.com)

## INSTALLATION DIFFICULTY



Skills Needed: (Please refer to installation difficulty chart on website for additional information)

- Professional installation required

Dimensions can be found in Product Specifications Table on reverse side.

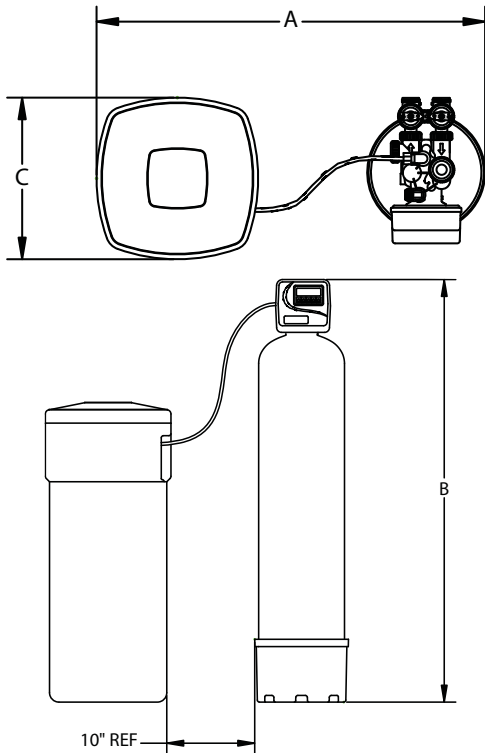

## Models: 3MWTS100/3MWTS150/3MWTS200

## SPECIFICATIONS

Category	Model		
	3MWTS100	3MWTS150	3MWTS200
<b>Media in cu. ft. (liters)</b>	1.0 (28)	1.5 (42)	2.0 (57)
<b>Salt Dosage*</b> lbs. (kg)	4.0 (1.81)	6.0 (2.72)	8.0 (3.63)
	6.0 (2.72)	9.0 (4.08)	12.0 (5.44)
	16.0 (7.26)	16.0 (7.26)	24.0 (10.89)
<b>Softening Capacity**</b> (grains)	16,300	24,200	34,100
	21,600	32,000	45,000
	29,000	43,000	56,800
<b>Flow Rate</b> Service: 15 psid	11.0 gpm	13.5 gpm	14.3 gpm
	(41.6 lpm)	(51.1 lpm)	(54.1 lpm)

\* Salt Dosage: Top row indicates salt efficient setting, second row indicates factory setting and third row indicates maximum setting with the supplied brine tank

\*\*Softening Capacity: Top row indicates salt efficient setting, second row indicates factory salt setting and third row indicates maximum salt setting with the supplied brine tank

NOTE: 3MWTS Softeners have been tested by an independent lab for conformance to NSF/ANSI Standard 44 for specific performance claims. These softeners meet or exceed California Salt Efficiency requirements when salt dose is set at the salt efficient setting. Efficiency claim is only valid at the salt efficiency setting.

## IMPORTANT

⚠ **WARNING:** To reduce the risk associated with the ingestion of contaminants:

- Do not use with water that is microbiologically unsafe or of unknown quality without adequate disinfection before or after the system.

**CAUTION:** To reduce the risk associated with property damage due to water leakage:

- Read and follow Use Instructions before installation and use of this system.

3M recommends regularly scheduled maintenance and replacement of the filter media in order for the product to perform as advertised. 3M Purification Inc. shall not be liable for system failures due to improper maintenance.

## LIMITED WARRANTY

3M Purification Inc. warrants this Product will be free from defects in material and manufacture for the following periods from the date of purchase.

- Ten (10) years on the filter tank
- Ten (10) years on salt brine tank
- Five (5) years on the valve body
- Five (5) years on the electronics

This warranty does not cover failures resulting from abuse, misuse, alteration or damage not caused by 3M Purification Inc. or failure to follow installation and use instructions. No warranty is given as to the service life of any filter cartridge, as it will vary with local water conditions and water consumption. **3M Purification Inc. MAKES NO OTHER WARRANTIES OR CONDITIONS, EXPRESS OR IMPLIED, INCLUDING, BUT NOT LIMITED TO, ANY IMPLIED WARRANTY OR CONDITION OF MERCHANTABILITY OR FITNESS FOR A PARTICULAR PURPOSE OR ANY IMPLIED WARRANTY OR CONDITION ARISING OUT OF A COURSE OF DEALING, CUSTOMER OR USAGE OF TRADE.** If the Product fails to satisfy this Limited Warranty during the warranty period, 3M will replace the Product or refund your Product purchase price. This warranty does not cover labor. **The remedy stated in this paragraph is Customer's sole remedy and 3M Purification Inc.'s exclusive obligation. For additional information, see the entire Limited Warranty located in the product Installation and Operating Instruction Manual.**

**Limitation of Liability.** 3M Purification Inc. will not be liable for any loss or damage arising from this 3M Purification Inc. product, whether direct, indirect, special, incidental, or consequential, regardless of the legal theory asserted, including warranty, contract, negligence or strict liability. Some states and countries do not allow the exclusion or limitation of incidental or consequential damages, so the above limitation or exclusion may not apply to you.

3M Purification Inc.  
400 Research Parkway  
Meriden, CT 06450  
855-3M-WATER (855-369-2837)  
www.3MWater.com