

## Snapshot

The OptiPure® OP350/50 Water Treatment System utilizes reverse osmosis (RO) to remove >97% of the total dissolved solids (TDS) from water. Then a balance of minerals is dissolved into the RO water to provide desirable “Optimized” water TDS. The system operates at line pressure and can produce up to 350 gallons per day of optimal quality water for applications where TDS reduction or the removal of the majority of hardness minerals is required. The OP350/50 is a complete system that includes integrated pre-filtration with particulate and chlorine reduction, reverse osmosis and mineral addition in a space saving, wall-mount or undercounter design. Adjustable Reject Flow Control allows precise adjustment of Product/Reject Ratio. A built-in full system bypass valve and sample port assures no service interruption and simplifies routine maintenance. Also included is a 50 gallon atmospheric storage tank with a top-mounted variable-flow repressurization system and a sub-micron air breather. Hose, tubing and fittings required for installation are included.

## System Benefits

- Virtually eliminates scale & corrosion problems related to high TDS & water hardness and reduce the potential for corrosion related to water chemistry.
- The QTMA secondary mineral addition system adds desirable TDS to provide balanced, buffered Optimized water.
- High capacity parallel pre-filtration protects the RO membrane and assures consistent performance for up to one year between pre-filter replacements.
- Compact, Modular Design enables installation under counters and in very tight spaces.
- Maximize equipment operating and energy efficiency.
- Adjustable Reject Flow Control minimizes water use due to seasonal fluctuations in water temperature.
- Dual-read digital TDS meter provides push-button monitoring of membrane performance and optimized water quality.
- Sample Port allows quick and simple system checks and adjustments.
- Built-in pressure gauge allows visual monitoring of operating pressure.
- Integrated system bypass valve eliminates down-time or service interruptions.
- All consumables are easy-to-change Qwik-Twist cartridges.
- Simple, easy-to-service and maintain design.

ITEM #: \_\_\_\_\_ QTY: \_\_\_\_\_  
JOB NAME/NUMBER \_\_\_\_\_



## Application

Any foodservice equipment where it is desirable to remove existing TDS (total dissolved solids) and provide a consistent balance of buffered TDS to minimize problems associated with high TDS, high hardness, high chlorides or any other TDS-related problems.

## Installation Tips

- Feed-water connection to system should be COLD only.
- Do not exceed system specifications for temperature and pressure.
- Provide a dedicated 1/2" water line to the unit for consistent flow and pressure to the system.
- Allow 3" clearance below system for filter cartridge removal and replacement.
- Connect filtered water line to steam production connections only. Do not use for condenser water.
- Detailed installation, operation & maintenance manual is included with each system.
- Mount the OP350/50 where it can be easily serviced.

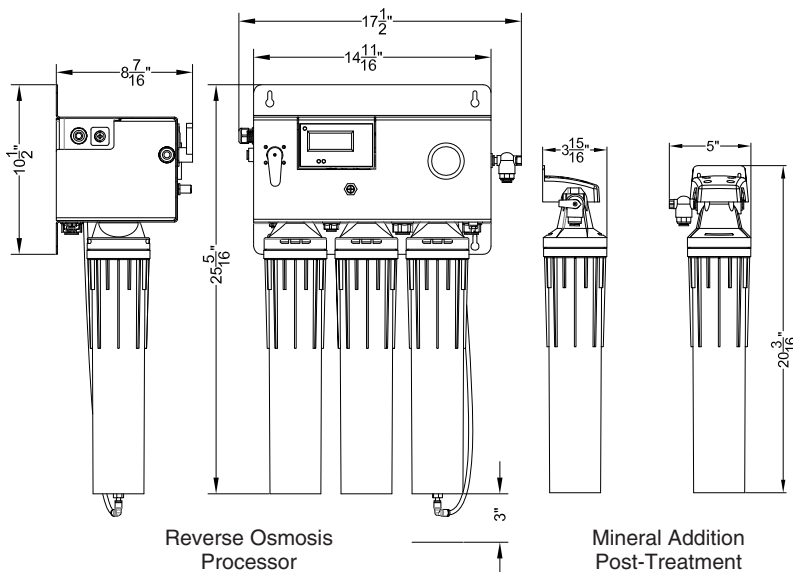

Reverse Osmosis Processor

Mineral Addition Post-Treatment

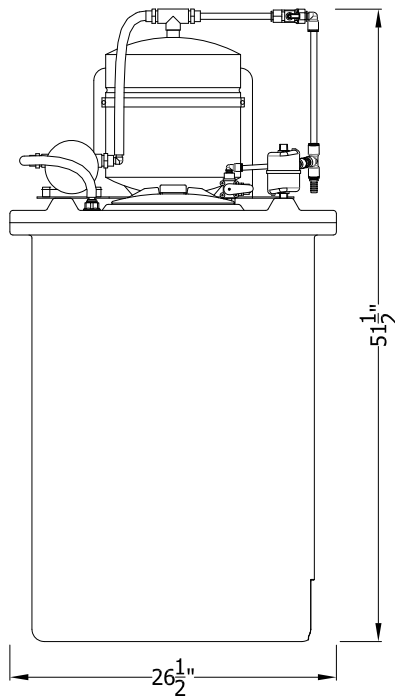

Repressurization/Storage Tank Assembly

Note: Repressurization Pump/ Buffer Tank Stand Assembly can be removed from top of tank and placed on floor or shelf in close proximity of the tank. Use Remote Kit PN: 164-89150.

### Feed-Water Chemistry

Feed TDS	Up to 1200 ppm
Feed pH	6-10
Hardness*	12 grains or less
Free Chlorine	<2 mg/l
Iron	0.1 mg/l max
Turbidity	0.05 NTU
Manganese	0.05 mg/l max
Hydrogen Sulfide	0.0 mg/l

\*For water outside of these parameters call OptiPure technical service.

## Specifications

System		
Dimensions	RO Processor	25.3" h x 17.5" w x 8.4" d
	Repressurization/Storage Tank	51.5" h x 26.5" dia.
	Mineral Addition Post-Treatment	20.2" h x 5" w x 3.9" d
Connection - Feedwater	3/8" Push Fit Tubing	
Operating Pressure Range	60-85 psi at 0.5 gpm (3.5 -5.9 bar)	
Inlet Water Temperature Range	40° -100° F (4° -38° C)	
Shipping Weight	25 lbs.	
Drain Connection (Within 5' of unit)	2 GPM Minimum Flow	
Performance		
Typical TDS* Rejection	97+%	
Product Water Production (at 77°F, 60psi)	350 gals/day 14.6 gals/hr 0.25 gpm	
<i>Production rate is strictly dependent on feed water temperature and pressure.</i>		
Typical Optimized Water TDS	40-80 ppm	

## Replacement Media

Description	Part Number	Qty
CTO-Q Pre-Filters	300-05830	2
AMS-QT Membrane	204-53040	1
MA-Q15 Post-Treatment	300-05855	1

It is recommended that Pre-Filters and Mineral Addition Cartridge be changed every 6 months, when capacity is reached or when feedwater pressure or flow becomes inadequate. Membrane life varies depending on feedwater conditions and PreFilter maintenance. 12-18 months under typical conditions but it can be as long as 3-5 years.

## Options

Description	Part Number
ScaleX2 Pre-Treatment	160-52101
QT10-1 CTO Post-Treatment	160-52009
BPS-QT Booster Pump	164-85020
FX-11CR Chloramine Reduction System	160-50011
PRV- Pressure Reducing Valve	164-89938

This product is for commercial use only and must be installed and maintained according to manufacturers guidelines.

Do not use on water that is microbiologically unsafe or of unknown quality without adequate disinfection before or after the system.

## Warranty

Systems have a 1 year warranty against defects in material and workmanship. Warranty does not include filters or membranes. For complete warranty information contact OptiPure customer service or go to the OptiPure website.

OP350\_50specRev1

Dealer/Distributor Info:

Mfg. by OptiPure div. of Procam Controls, Inc.  
2605 Technology Dr., Bldg 300 Plano, TX 75074  
p: 972.881.9797; f: 972.422.6262  
e: info@optipure.net [www.optipurewater.com](http://www.optipurewater.com)